



LCD Module Technical Specification

First Edition
May 2, 2000

Final Revision

Type No. **DMF-51026NY-LY**

Approved by (Production Div.)

Checked by (Quality Assurance Div.)

Checked by (Design Engineering Div.)

Prepared by (Production Div.)

Table of Contents

1. General Specifications.....	2
2. Electrical Specifications.....	3
3. Optical Specifications.....	8
4. I/O Terminal.....	10
5. Test.....	12
6. Appearance Standards.....	13
7. Code System of Production Lot.....	16
8. Type Number.....	16
9. Applying Precautions.....	16
10. Precautions Relating Product Handling.....	17
11. Warranty.....	18

Revision History

Rev.	Date	Page	Comment

1. General Specifications

Operating Temp.	:	min. 0°C ~max. 50°C
Storage Temp.	:	min. -20°C ~max. 60°C
Dot Pixels	:	160 (W) × 64 (H) dots
Dot Size	:	0.34 (W) × 0.34 (H) mm
Dot Pitch	:	0.37 (W) × 0.37 (H) mm
Viewing Area	:	62.4 (W) × 27.6 (H) mm
Outline Dimensions	:	89.0 (W) × 35.6 (H) × 13.9max.* (D) mm * Without I/O Connector
Weight	:	60g max.
LCD Type	:	NTD-12641 (STN / Yellow-mode / Transmissive)
Viewing Angle	:	6:00
Data Transfer	:	4-bit parallel data transfer
Backlight	:	LED Backlight / Yellow-green
Drawings	:	Dimensional Outline UE-300213

2. Electrical Specifications

2.1. Absolute Maximum Ratings

V_{SS}=0V

Parameter	Symbol	Conditions	Min.	Max.	Units
Supply Voltage (Logic)	V _{CC} -V _{SS}	-	-0.3	7.0	V
Supply Voltage (LCD Drive)	V _{CC} -V _{EE}	-	0	30.0	V
Input Voltage	V _I	-	-0.3	V _{CC} +0.3	V

2.2. DC Characteristics

T_a=25°C, V_{SS}=0V

Parameter	Symbol	Conditions	Min.	Typ.	Max.	Units
Supply Voltage (Logic)	V _{CC} -V _{SS}	-	4.5	-	5.5	V
Supply Voltage (LCD Drive)	V _{CC} -V _{EE}	-	15.6	-	28.0	V
	V _{CC} -V _{ADJ}	Shown in 3.1				V
High Level Input Voltage	V _{IH}	V _{CC} =5.0V±10%	0.7×V _{CC}	-	V _{CC}	V
Low Level Input Voltage	V _{IL}	V _{CC} =5.0V±10%	0	-	0.3×V _{CC}	V
Supply Current	I _{CC}	V _{CC} -V _{SS} =5.0V	-	0.9	1.4	mA
	I _{EE}	V _{CC} -V _{ADJ} =13.5V	-	0.8	1.2	mA

2.3.AC Characteristics

V_{CC}=5.0V±10%

Parameter	Symbol	Min.	Max.	Units
Clock Pulse Cycle Time	t _{CYC}	125	-	ns
Clock Pulse High Level Width	t _{CWH}	40	-	ns
Clock Pulse Low Level Width	t _{CWL}	40	-	ns
Clock Pulse Setup Time	t _{SCL}	80	-	ns
Clock Pulse Hold Time	t _{HCL}	80	-	ns
Clock Pulse Rise/Fall Time	t _r , t _f	-	Note1	ns
LP High Level Width	t _{LWH}	80	-	ns
LP Low Level Width	t _{LWL}	1.0	-	μs
LP Cycle Time	t _{CL1}	10	-	μs
Data Setup Time	t _{DS}	20	-	ns
Data Hold Time	t _{DH}	20	-	ns
FLM Data Setup Time	t _{FS}	100	-	ns
FLM Data Hold Time	t _{FH}	100	-	ns
M Phase Difference	t _{CM}	-	300	ns

Note1: Please satisfy the following conditions (1),(2) in the same time.

(1) $t_r, t_f < (t_{CYC} - t_{CWH} - t_{CWL})/2$

(2) $t_r, t_f \leq 50$

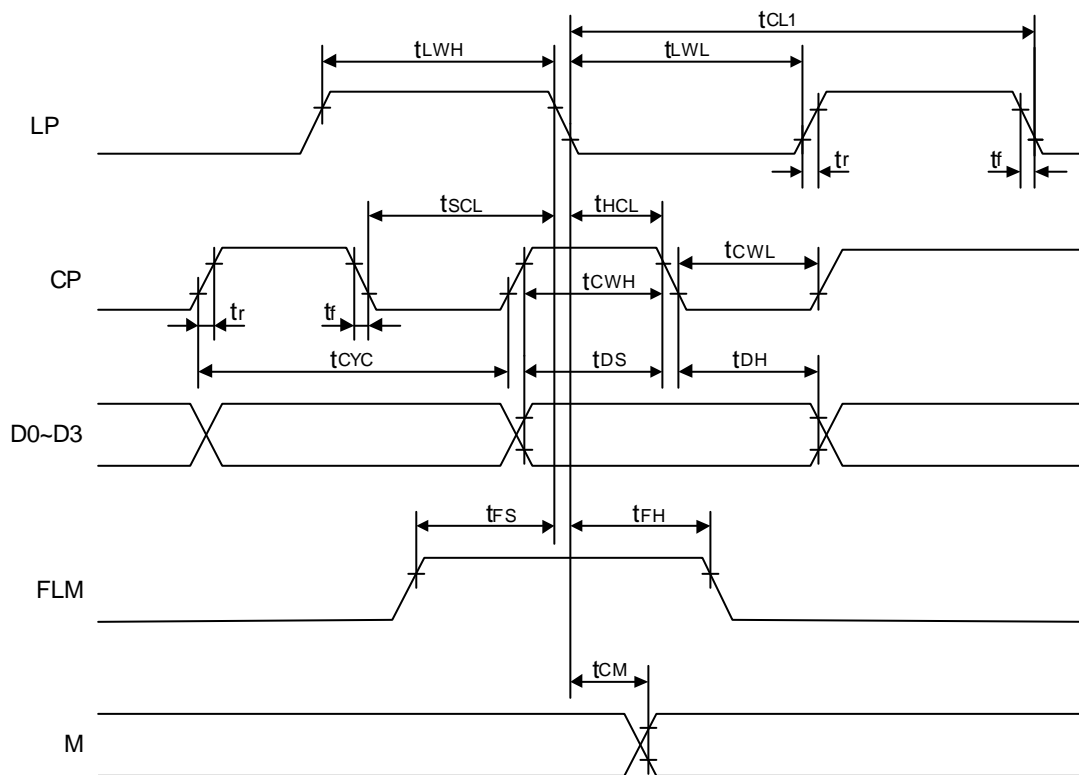

2.4. Timing Chart

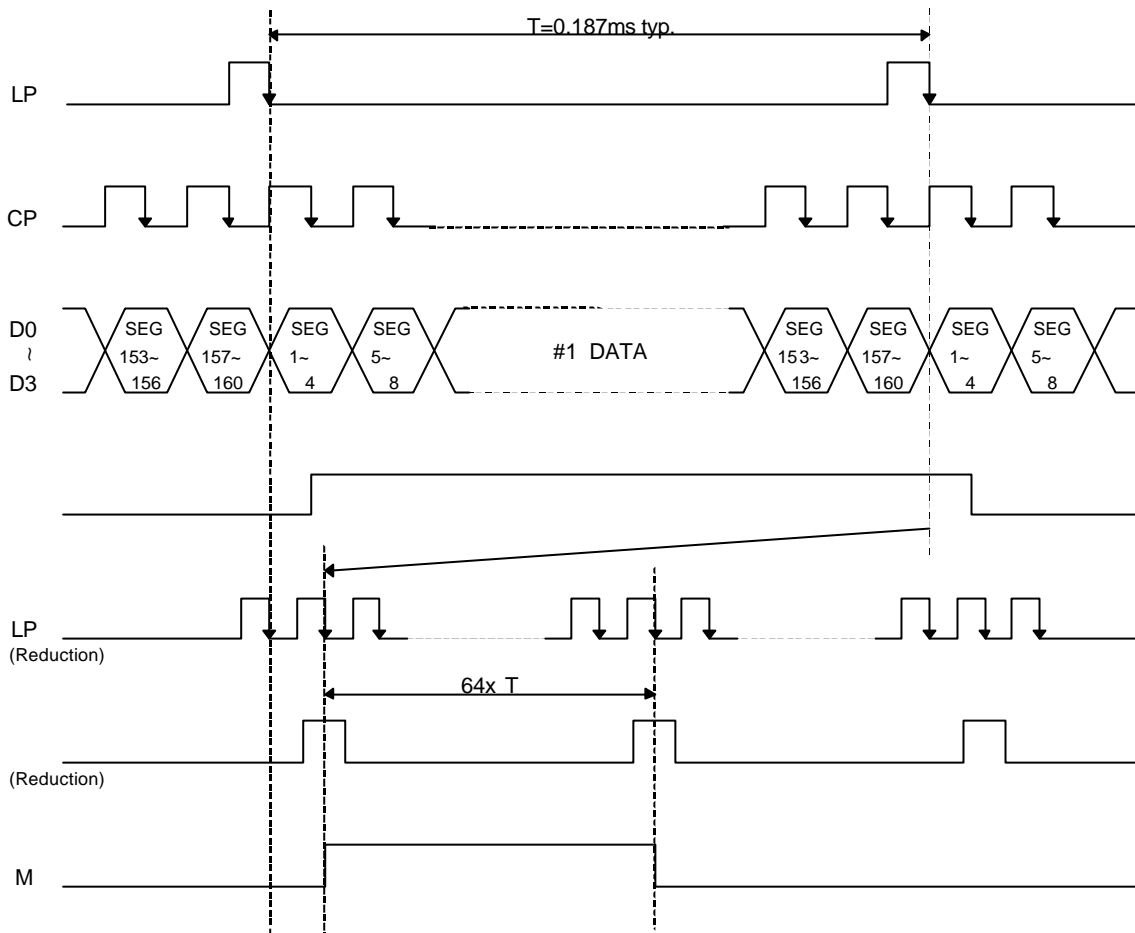

2.5. Comparison of Display and Data

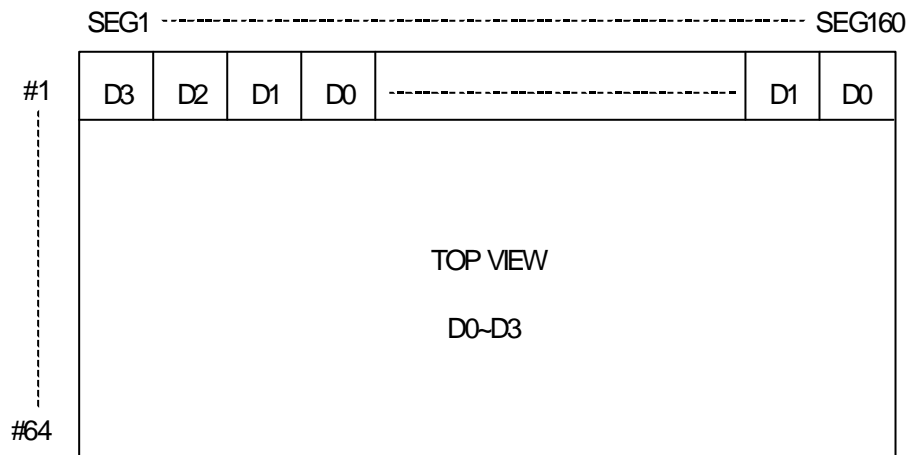

2.6. Power Supply ON/OFF Sequence

2.6.1. ON Sequence

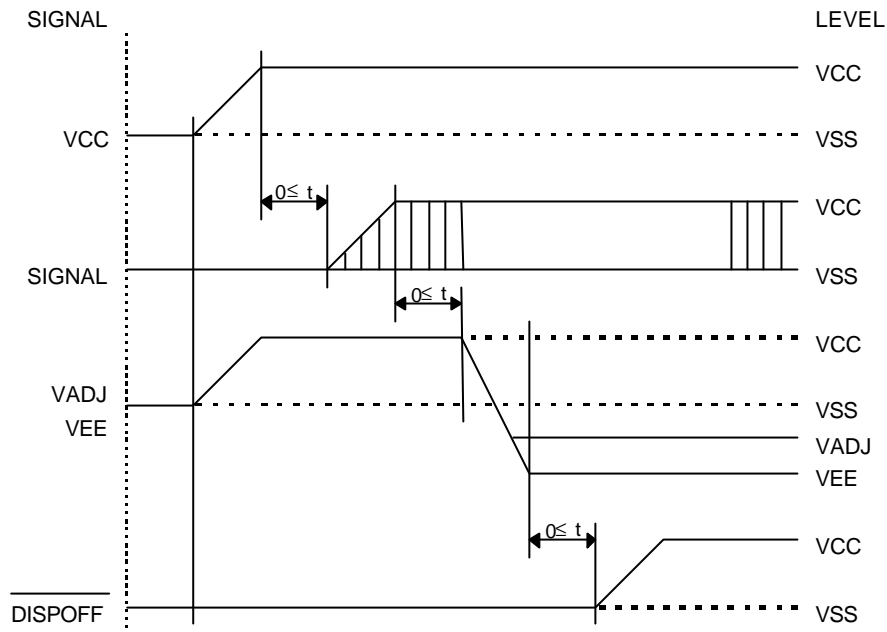

2.6.2. OFF Sequence

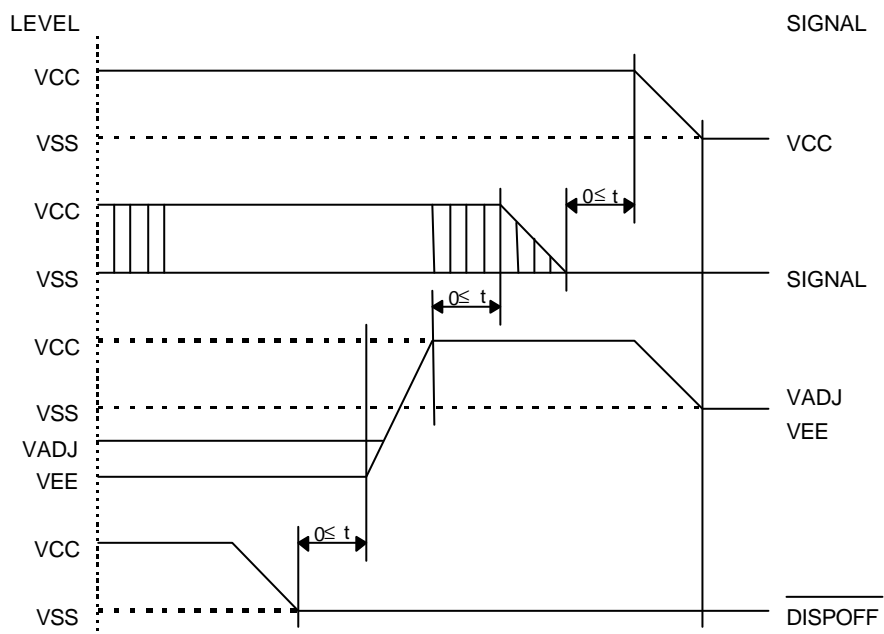

Please maintain the above sequence when turning on and off the power supply of the module.

If DISPOFF is supplied to the module while internal alternate signal for LCD driving (M) is unstable, DC component will be supplied to the LCD panel. This may cause damage the LCD module.

Optical Specifications

2.8.LCD Driving Voltage

Parameter	Symbol	Conditions	Min.	Typ.	Max.	Units
Recommended LCD Driving Voltage Note 1	V _{CC} -V _{ADJ}	T _a = 0°C	-	-	15.6	V
		T _a =25°C	12.6	13.5	14.4	V
		T _a =50°C	11.5	-	-	V

Note 1 : Voltage (Applied actual waveform to LCD Module) for the best contrast. The range of minimum and maximum shows tolerance of the operating voltage. The specified contrast ratio and response time are not guaranteed over the entire range.

2.9.Optical Characteristics

T_a=25°C, 1/64 Duty, 1/9 Bias, V_D=12.8V (Note 4), θ= 0°, φ= - °

Parameter	Symbol	Conditions	Min.	Typ.	Max.	Units
Contrast Ratio Note 1	CR	θ= 0°, φ= - °	-	7	-	
Viewing Angle		Shown in 3.3				
Response Time	Rise Note 2	T _{ON}	-	160	240	ms
	Decay Note 3	T _{OFF}	-	160	240	ms

Note 1 : Contrast ratio is defined as follows. (CR = L_{OFF} / L_{ON})

L_{ON} : Luminance of the ON segments

L_{OFF} : Luminance of the OFF segments

Note 2 : The time that the luminance level reaches 90% of the saturation level from 0% when ON signal is applied.

Note 3 : The time that the luminance level reaches 10% of the saturation level from 100% when OFF signal is applied.

Note 4 : Definition of Driving Voltage V_D

$$V_D = V_{CC} - V_{ADJ} - V_{BE}$$

Assuming that the typical driving waveforms shown below are applied to the LCD Panel at 1/A Duty - 1/B Bias (A : Duty Number, B : Bias Number). Driving voltage V_D is defined as follows.

$$V_D = (V_{th1} + V_{th2}) / 2$$

V_{th1} : The voltage V_{O-P} that should provide 50% of the saturation level in the luminance at the segment which the ON signal is applied to.

V_{th2} : The voltage V_{O-P} that should provide 50% of the saturation level in the luminance at the segment which the OFF signal is applied to.

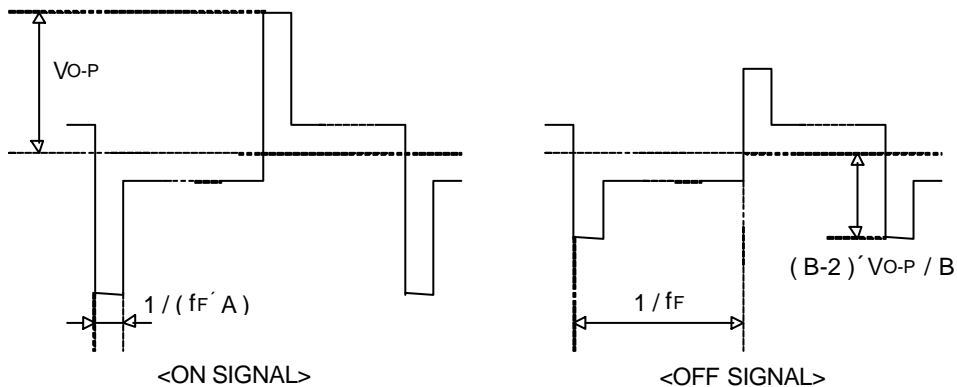

2.10. Definition of Viewing Angle and Optimum Viewing Area

*Point ● shows the point where contrast ratio is measured. : $\theta = 0^\circ$, $\phi = 0^\circ$

*Driving condition : 1/64 Duty, 1/9 Bias, $V_D = 12.8V$, $f_F = 83.7Hz$

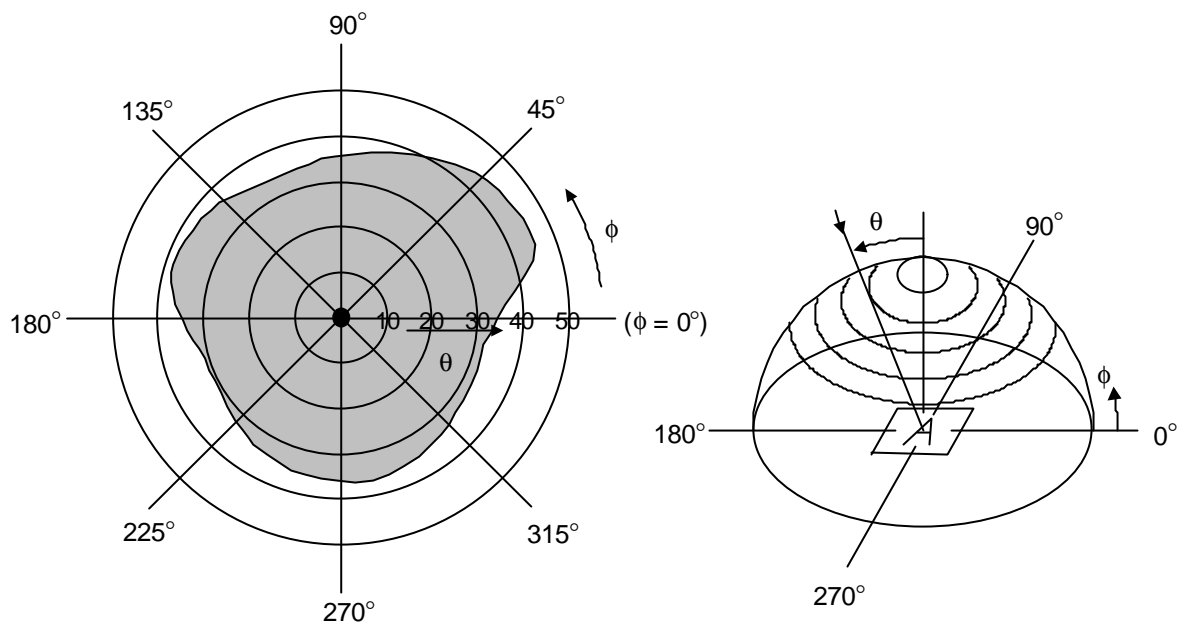

*Area  shows typ. $CR \geq 2$

2.11. System Block Diagram

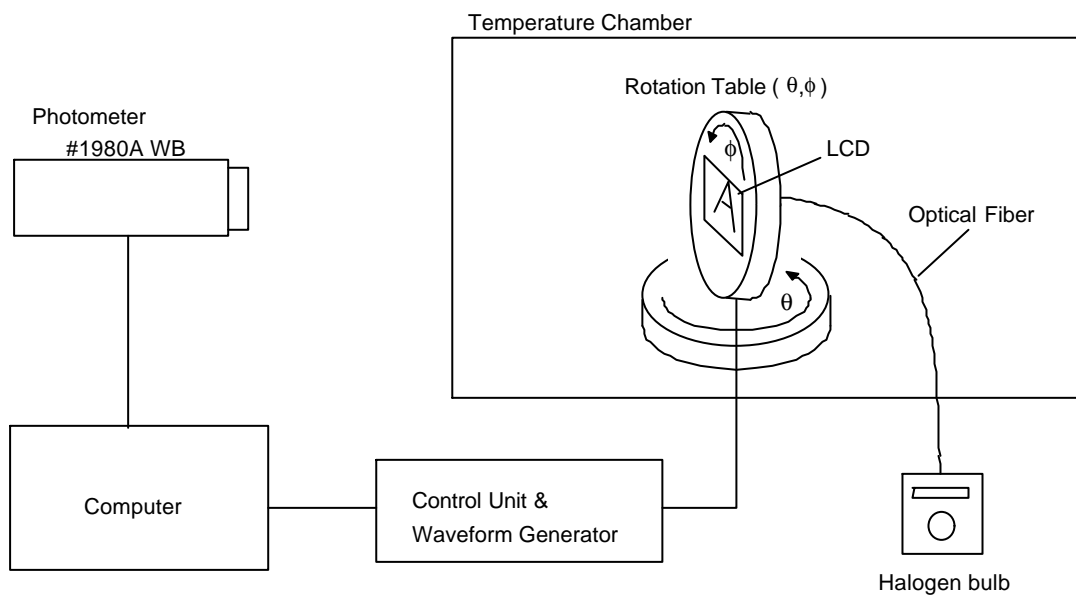

3.I/O Terminal

3.1.Pin Assignment

CN1

No.	Symbol	Function
1	FLM	First Line Marker
2	LP	Data Latch Signal
3	CP	Clock Signal for Shifting Data
4	M	Alternate Signal for LCD Drive
5	V _{ADJ}	Voltage Level for LCD Contrast Adjustment
6	V _{CC}	Power Supply for Logic
7	V _{SS}	Power Supply (0V, GND)
8	V _{EE}	Power Supply for LCD Drive
9	D0	Display Data
10	D1	Display Data
11	D2	Display Data
12	D3	Display Data
13	$\overline{\text{DISPOFF}}$	Display Control Signal H : Display on L : Display off
14	ANODE	LED Anode Terminal
15	CATHODE	LED Cathode Terminal

3.2.Example of Power Supply

It is recommended to apply a potentiometer for the contrast adjust due to the tolerance of the driving voltage and its temperature dependence.

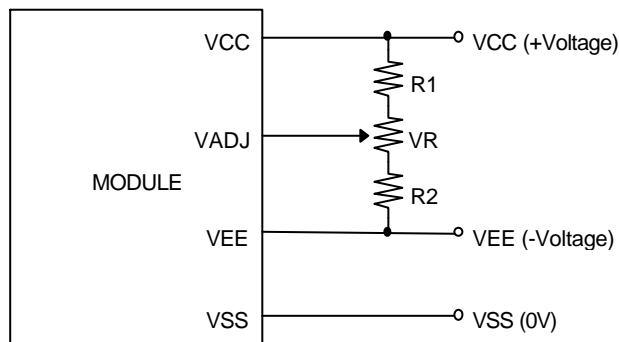

$$R1+R2+VR=10-20K\Omega$$

3.3. Block Diagram

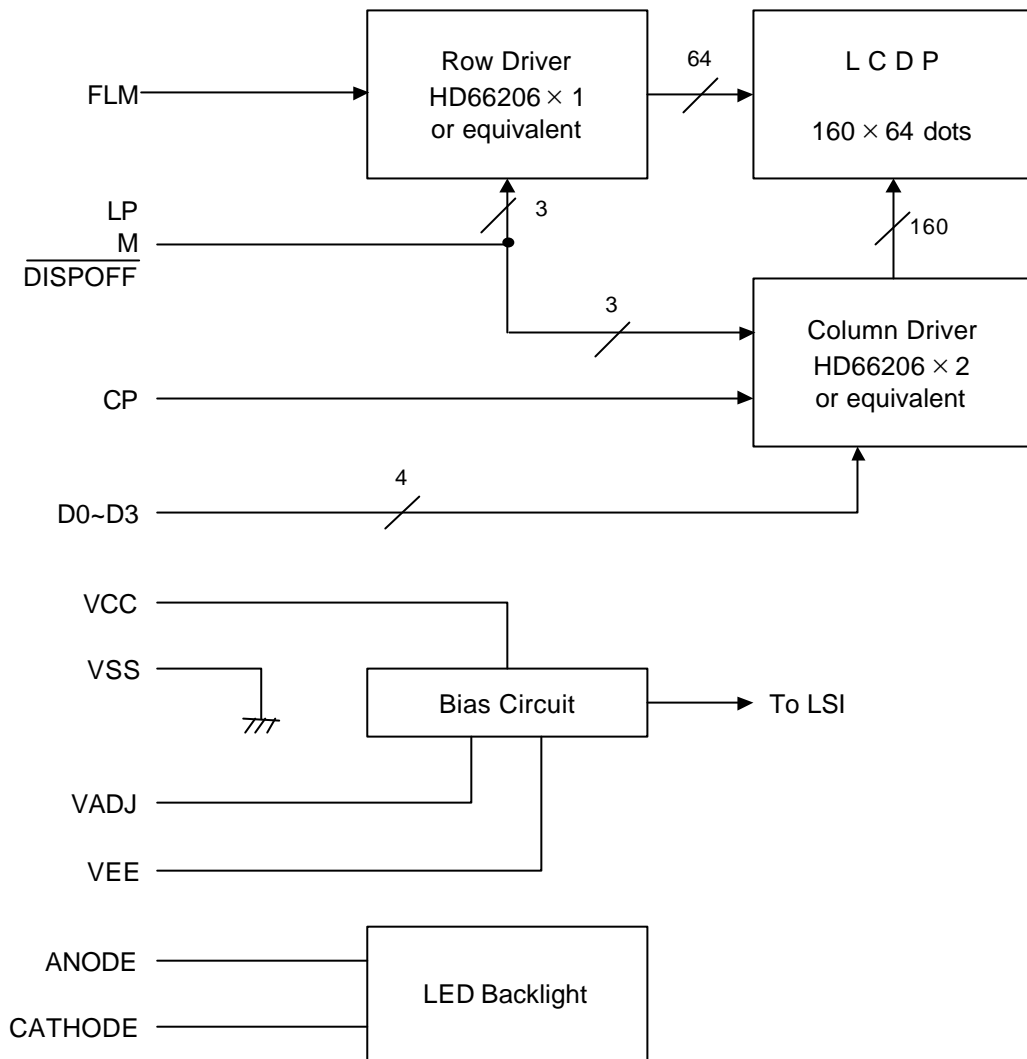

4. Test

No change on display and in operation under the following test condition.

Conditions: Unless otherwise specified, tests will be conducted under the following condition.

Temperature: $20 \pm 5^\circ\text{C}$

Humidity : $65 \pm 5\% \text{RH}$

tests will be not conducted under functioning state.

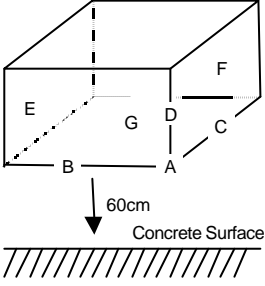
No.	Parameter	Conditions	Notes
1	High Temperature Operating	$50^\circ\text{C} \pm 2^\circ\text{C}$, 96hrs (operation state)	
2	Low Temperature Operating	$0^\circ\text{C} \pm 2^\circ\text{C}$, 96hrs (operation state)	1
3	High Temperature Storage	$60^\circ\text{C} \pm 2^\circ\text{C}$, 96hrs	2
4	Low Temperature Storage	$-20^\circ\text{C} \pm 2^\circ\text{C}$, 96hrs	1,2
5	Damp Proof Test	$40^\circ\text{C} \pm 2^\circ\text{C}$, 90~95%RH, 96hrs	1,2
6	Vibration Test	Total fixed amplitude : 1.5mm Vibration Frequency : 10~55Hz One cycle 60 seconds to 3 directions of X, Y, Z for each 15 minutes	3
7	Shock Test	To be measured after dropping from 60cm high on the concrete surface in packing state. 	

Note 1 :No dew condensation to be observed.

Note 2 :The function test shall be conducted after 4 hours storage at the normal Temperature and humidity after removed from the test chamber.

Note 3 :Vibration test will be conducted to the product itself without putting it in a container.

5.Appearance Standards

5.1.Inspection conditions

The LCD shall be inspected under 40W white fluorescent light.

The distance between the eyes and the sample shall be more than 30cm.

All directions for inspecting the sample should be within 45°against perpendicular line.

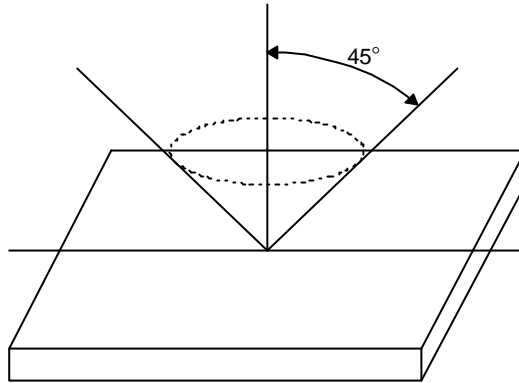

5.2.Definition of applicable Zones

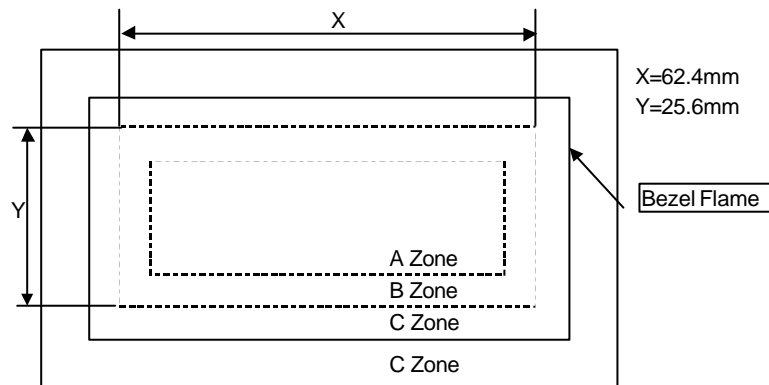

A Zone : Active display area

B Zone : Area from outside of "A Zone" to validity viewing area

C Zone : Rest parts

A Zone + B Zone = Validity viewing area

5.3. Standards

No.	Parameter	Criteria																																																										
1	Black and White Spots, Foreign Substances	<p>(1) Round Shape</p> <table border="1" data-bbox="603 320 1366 658"> <thead> <tr> <th data-bbox="603 320 906 365">Zone</th> <th colspan="3" data-bbox="906 320 1366 365">Acceptable Number</th> </tr> <tr> <th data-bbox="603 365 906 409">Dimension (mm)</th> <th data-bbox="906 365 1062 409">A</th> <th data-bbox="1062 365 1219 409">B</th> <th data-bbox="1219 365 1366 409">C</th> </tr> </thead> <tbody> <tr> <td data-bbox="603 409 906 454">$D \leq 0.1$</td> <td data-bbox="906 409 1062 454">*</td> <td data-bbox="1062 409 1219 454">*</td> <td data-bbox="1219 409 1366 454">*</td> </tr> <tr> <td data-bbox="603 454 906 499">$0.1 < D \leq 0.2$</td> <td data-bbox="906 454 1062 499">3</td> <td data-bbox="1062 454 1219 499">5</td> <td data-bbox="1219 454 1366 499">*</td> </tr> <tr> <td data-bbox="603 499 906 544">$0.2 < D \leq 0.25$</td> <td data-bbox="906 499 1062 544">2</td> <td data-bbox="1062 499 1219 544">3</td> <td data-bbox="1219 499 1366 544">*</td> </tr> <tr> <td data-bbox="603 544 906 589">$0.25 < D \leq 0.3$</td> <td data-bbox="906 544 1062 589">0</td> <td data-bbox="1062 544 1219 589">1</td> <td data-bbox="1219 544 1366 589">*</td> </tr> <tr> <td data-bbox="603 589 906 658">$0.3 < D$</td> <td data-bbox="906 589 1062 658">0</td> <td data-bbox="1062 589 1219 658">0</td> <td data-bbox="1219 589 1366 658">*</td> </tr> </tbody> </table> <p data-bbox="603 667 1075 703">$D = (\text{Long} + \text{Short}) / 2$ * : Disregard</p> <p>(2) Line Shape</p> <table border="1" data-bbox="603 748 1366 1039"> <thead> <tr> <th colspan="2" data-bbox="603 748 906 792">Zone</th> <th colspan="3" data-bbox="906 748 1366 792">Acceptable Number</th> </tr> <tr> <th data-bbox="603 792 759 837">X (mm)</th> <th data-bbox="759 792 906 837">Y (mm)</th> <th data-bbox="906 792 1062 837">A</th> <th data-bbox="1062 792 1219 837">B</th> <th data-bbox="1219 792 1366 837">C</th> </tr> </thead> <tbody> <tr> <td data-bbox="603 837 759 882">-</td> <td data-bbox="759 837 906 882">$0.03 \geq W$</td> <td data-bbox="906 837 1062 882">*</td> <td data-bbox="1062 837 1219 882">*</td> <td data-bbox="1219 837 1366 882">*</td> </tr> <tr> <td data-bbox="603 882 759 927">$2.0 \geq L$</td> <td data-bbox="759 882 906 927">$0.05 \geq W$</td> <td data-bbox="906 882 1062 927">3</td> <td data-bbox="1062 882 1219 927">3</td> <td data-bbox="1219 882 1366 927">*</td> </tr> <tr> <td data-bbox="603 927 759 972">$1.0 \geq L$</td> <td data-bbox="759 927 906 972">$0.1 \geq W$</td> <td data-bbox="906 927 1062 972">3</td> <td data-bbox="1062 927 1219 972">3</td> <td data-bbox="1219 927 1366 972">*</td> </tr> <tr> <td data-bbox="603 972 759 1039">-</td> <td data-bbox="759 972 906 1039">$0.1 < W$</td> <td colspan="3" data-bbox="906 972 1366 1039">In the same way (1)</td> </tr> </tbody> </table> <p data-bbox="603 1048 1046 1084">X : Length Y : Width * : Disregard</p> <p data-bbox="603 1093 963 1128">Total defects shall not exceed 5.</p>	Zone	Acceptable Number			Dimension (mm)	A	B	C	$D \leq 0.1$	*	*	*	$0.1 < D \leq 0.2$	3	5	*	$0.2 < D \leq 0.25$	2	3	*	$0.25 < D \leq 0.3$	0	1	*	$0.3 < D$	0	0	*	Zone		Acceptable Number			X (mm)	Y (mm)	A	B	C	-	$0.03 \geq W$	*	*	*	$2.0 \geq L$	$0.05 \geq W$	3	3	*	$1.0 \geq L$	$0.1 \geq W$	3	3	*	-	$0.1 < W$	In the same way (1)		
Zone	Acceptable Number																																																											
Dimension (mm)	A	B	C																																																									
$D \leq 0.1$	*	*	*																																																									
$0.1 < D \leq 0.2$	3	5	*																																																									
$0.2 < D \leq 0.25$	2	3	*																																																									
$0.25 < D \leq 0.3$	0	1	*																																																									
$0.3 < D$	0	0	*																																																									
Zone		Acceptable Number																																																										
X (mm)	Y (mm)	A	B	C																																																								
-	$0.03 \geq W$	*	*	*																																																								
$2.0 \geq L$	$0.05 \geq W$	3	3	*																																																								
$1.0 \geq L$	$0.1 \geq W$	3	3	*																																																								
-	$0.1 < W$	In the same way (1)																																																										
2	Air Bubbles (between glass & polarizer)	<table border="1" data-bbox="603 1178 1366 1469"> <thead> <tr> <th data-bbox="603 1178 906 1223">Zone</th> <th colspan="3" data-bbox="906 1178 1366 1223">Acceptable Number</th> </tr> <tr> <th data-bbox="603 1223 906 1267">Dimension (mm)</th> <th data-bbox="906 1223 1062 1267">A</th> <th data-bbox="1062 1223 1219 1267">B</th> <th data-bbox="1219 1223 1366 1267">C</th> </tr> </thead> <tbody> <tr> <td data-bbox="603 1267 906 1312">$D \leq 0.3$</td> <td data-bbox="906 1267 1062 1312">*</td> <td data-bbox="1062 1267 1219 1312">*</td> <td data-bbox="1219 1267 1366 1312">*</td> </tr> <tr> <td data-bbox="603 1312 906 1357">$0.3 < D \leq 0.4$</td> <td data-bbox="906 1312 1062 1357">3</td> <td data-bbox="1062 1312 1219 1357">*</td> <td data-bbox="1219 1312 1366 1357">*</td> </tr> <tr> <td data-bbox="603 1357 906 1402">$0.4 < D \leq 0.6$</td> <td data-bbox="906 1357 1062 1402">2</td> <td data-bbox="1062 1357 1219 1402">3</td> <td data-bbox="1219 1357 1366 1402">*</td> </tr> <tr> <td data-bbox="603 1402 906 1469">$0.6 < D$</td> <td data-bbox="906 1402 1062 1469">0</td> <td data-bbox="1062 1402 1219 1469">0</td> <td data-bbox="1219 1402 1366 1469">*</td> </tr> </tbody> </table> <p data-bbox="603 1478 772 1514">* : Disregard</p> <p data-bbox="603 1523 963 1559">Total defects shall not exceed 3.</p>	Zone	Acceptable Number			Dimension (mm)	A	B	C	$D \leq 0.3$	*	*	*	$0.3 < D \leq 0.4$	3	*	*	$0.4 < D \leq 0.6$	2	3	*	$0.6 < D$	0	0	*																																		
Zone	Acceptable Number																																																											
Dimension (mm)	A	B	C																																																									
$D \leq 0.3$	*	*	*																																																									
$0.3 < D \leq 0.4$	3	*	*																																																									
$0.4 < D \leq 0.6$	2	3	*																																																									
$0.6 < D$	0	0	*																																																									

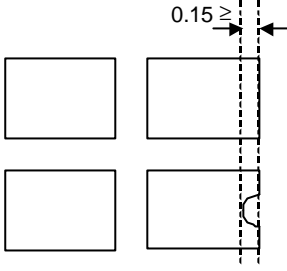
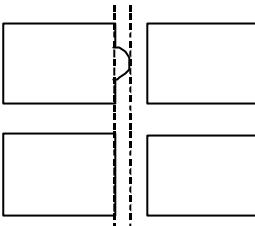
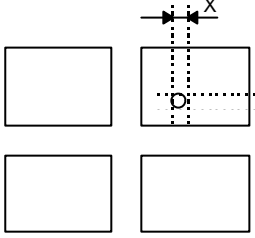
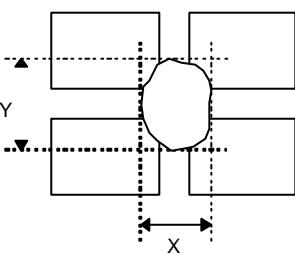
No.	Parameter	Criteria
3	The Shape of Dot	<p>(1) Dot Shape (with Dent)</p>  <p>As per the sketch of left hand.</p> <p>(2) Dot Shape (with Projection)</p>  <p>Should not be connected to next dot.</p> <p>(3) Pin Hole</p>  <p>$(X+Y) / 2 \leq 0.2\text{mm}$ (Less than 0.1mm is no counted.)</p> <p>(4) Deformation</p>  <p>$(X+Y) / 2 \leq 0.2\text{mm}$</p> <p>Total acceptable number : 1/dot, 5/cell (Defect number of (4) : 1pc.)</p>
4	Polarizer Scratches	Not to be conspicuous defects.
5	Polarizer Dirts	If the stains are removed easily from LCDP surface, the module is not defective.
6	Complex Foreign Substance Defects	Black spots, line shaped foreign substances or air bubbles between glass & polarizer should be 5pcs maximum in total.
7	Distance between Different Foreign Substance Defects	$D \leq 0.2$: 20mm or more $0.2 < D$: 40mm or more

6.Code System of Production Lot

The production lot of module is specified as follows.

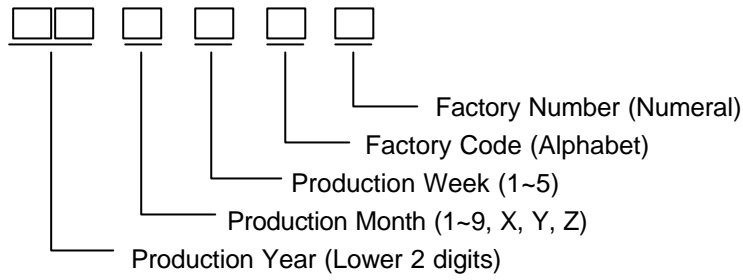

7.Type Number

The type number of module is specified as follows.

DMF-51026NY-LY

8.Applying Precautions

Please contact us when questions and/or new problems not specified in this specifications arise.

9. Precautions Relating Product Handling

The Following precautions will guide you in handling our product correctly.

- 1) Liquid crystal display devices
 1. The liquid crystal display device panel used in the liquid crystal display module is made of plate glass. Avoid any strong mechanical shock. Should the glass break handle it with care.
 2. The polarizer adhering to the surface of the LCD is made of a soft material. Guard against scratching it.
- 2) Care of the liquid crystal display module against static electricity discharge.
 1. When working with the module, be sure to ground your body and any electrical equipment you may be using. We strongly recommend the use of anti static mats (made of rubber), to protect work tables against the hazards of electrical shock.
 2. Avoid the use of work clothing made of synthetic fibers. We recommend cotton clothing or other conductivity-treated fibers.
 3. Slowly and carefully remove the protective film from the LCD module, since this operation can generate static electricity.
- 3) When the LCD module alone must be stored for long periods of time:
 1. Protect the modules from high temperature and humidity.
 2. Keep the modules out of direct sunlight or direct exposure to ultraviolet rays.
 3. Protect the modules from excessive external forces.
- 4) Use the module with a power supply that is equipped with an overcurrent protector circuit, since the module is not provided with this protective feature.
- 5) Do not ingest the LCD fluid itself should it leak out of a damaged LCD module. Should hands or clothing come in contact with LCD fluid, wash immediately with soap.
- 6) Conductivity is not guaranteed for models that use metal holders where solder connections between the metal holder and the PCB are not used. Please contact us to discuss appropriate ways to assure conductivity.
- 7) For models which use CFL:
 1. High voltage of 1000V or greater is applied to the CFL cable connector area. Care should be taken not to touch connection areas to avoid burns.
 2. Protect CFL cables from rubbing against the unit and thus causing the wire jacket to become worn.
 3. The use of CFLs for extended periods of time at low temperatures will significantly shorten their service life.
- 8) For models which use touch panels:
 1. Do not stack up modules since they can be damaged by components on neighboring modules.
 2. Do not place heavy objects on top of the product. This could cause glass breakage.
- 9) For models which use COG, TAB, or COF:
 1. The mechanical strength of the product is low since the IC chip faces out unprotected from the rear. Be sure to protect the rear of the IC chip from external forces.
 2. Given the fact that the rear of the IC chip is left exposed, in order to protect the unit from electrical damage, avoid installation configurations in which the rear of the IC chip runs the risk of making any electrical contact.

10) Models which use flexible cable, heat seal, or TAB:

1. In order to maintain reliability, do not touch or hold by the connector area.
2. Avoid any bending, pulling, or other excessive force, which can result in broken connections.

11) In case of buffer material such as cushion / gasket is assembled into LCD module, it may have an adverse effect on connecting parts (LCD panel-TCP / HEAT SEAL / FPC / etc., PCB-TCP / HEAT SEAL / FPC etc., TCP-HEAT SEAL, TCP-FPC, HEAT SEAL-FPC, etc.,) depending on its materials.

Please check and evaluate these materials carefully before use.

12) In case of acrylic plate is attached to front side of LCD panel, cloudiness (very small cracks) can occur on acrylic plate, being influenced by some components generated from polarizer film.. Please check and evaluate those acrylic materials carefully before use.

10. Warranty

This product has been manufactured to your company's specifications as a part for use in your company's general electronic products. It is guaranteed to perform according to delivery specifications. For any other use apart from general electronic equipment, we cannot take responsibility if the product is used in medical devices, nuclear power control equipment, aerospace equipment, fire and security systems, or any other applications in which there is a direct risk to human life and where extremely high levels of reliability are required. If the product is to be used in any of the above applications, we will need to enter into a separate product liability agreement.

1. We cannot accept responsibility for any defect, which may arise from additional manufacturing of the product (including disassembly and reassembly), after product delivery.
2. We cannot accept responsibility for any defect, which may arise after the application of strong external force to the product.
3. We cannot accept responsibility for any defect, which may arise due to the application of static electricity after the product has passed your company's acceptance inspection procedures.
4. When the product is in CFL models, CFL service life and brightness will vary according to the performance of the inverter used, leaks, etc. We cannot accept responsibility for product performance, reliability, or defect, which may arise.
5. We cannot accept responsibility for intellectual property of a third party, which may arise through the application of our product to your assembly with exception to those issues relating directly to the structure or method of manufacturing of our product.
6. Optrex will not be held responsible for any quality guarantee issue for defect products judged as Optrex-origin longer than 2 (two) years from Optrex production or 1(one) year from Optrex, Optrex America, Optrex Europe, Display LC delivery which ever comes later.